



INSTRUCTION BULLETIN

No. 9008714
Machine: T16
Published: 07-2011
Rev. 00

NOTE: DO NOT DISCARD the Parts List from the Instruction Bulletin. Place the Parts List in the appropriate place in the machine manual for future reference. Retaining the Parts List will make it easier to reorder individual parts and will save the cost of ordering an entire kit.

NOTE: Numbers in parenthesis () are reference numbers for parts listed in Bill of Materials.

Installation instructions for **kit number 9008061**

SYNOPSIS:

This kit contains the parts needed to install a front bumper kit on T16 scrubbers.
Please follow step-by-step instructions.

SPECIAL TOOLS / CONSIDERATIONS: NONE

(Estimated time to complete: 1 hour)



PROTECT THE ENVIRONMENT

Please dispose of packaging materials, old machine components, and hazardous fluids in an environmentally safe manner according to local waste disposal regulations.

Always remember to recycle.

PREPARATION:

1. Park the machine on a clean level surface, turn off the machine, and remove the key.

FOR SAFETY: Before leaving or servicing machine, stop on level surface, turn off machine, and remove key.

INSTALLATION:

1. Remove both bumper wheels from the front of the machine. Set both bumper wheels and M10 crown nuts aside. Discard both hex screws. Refer to Fig. 1 and Fig. 2.



FIG. 1

2. Use four M8 SEMS hex screws (4) to install the bumper mounting angle (3) onto the frame of the machine. Refer to Fig. 2.
3. Use two M10 hex screws (5) and two flat washers (6) to install the bumper weldment (2) onto the bumper mounting angle (3) installed onto the machine in the previous step. Do not completely tighten the hex screws. The M10 hex screws are tightened later in the procedure. Refer to Fig. 2.
4. Use two M10 hex screws (7) and the saved M10 crown nuts to reinstall the bumper wheels into the roller brackets and secure the bumper weldment (2) to the roller brackets. Refer to Fig. 2.
5. Tighten the M10 hex screws (5) installed in Step 3. Refer to Fig. 2.
6. Insert the black nylon plugs (1) into the bumper weldment (2). Refer to Fig. 2.

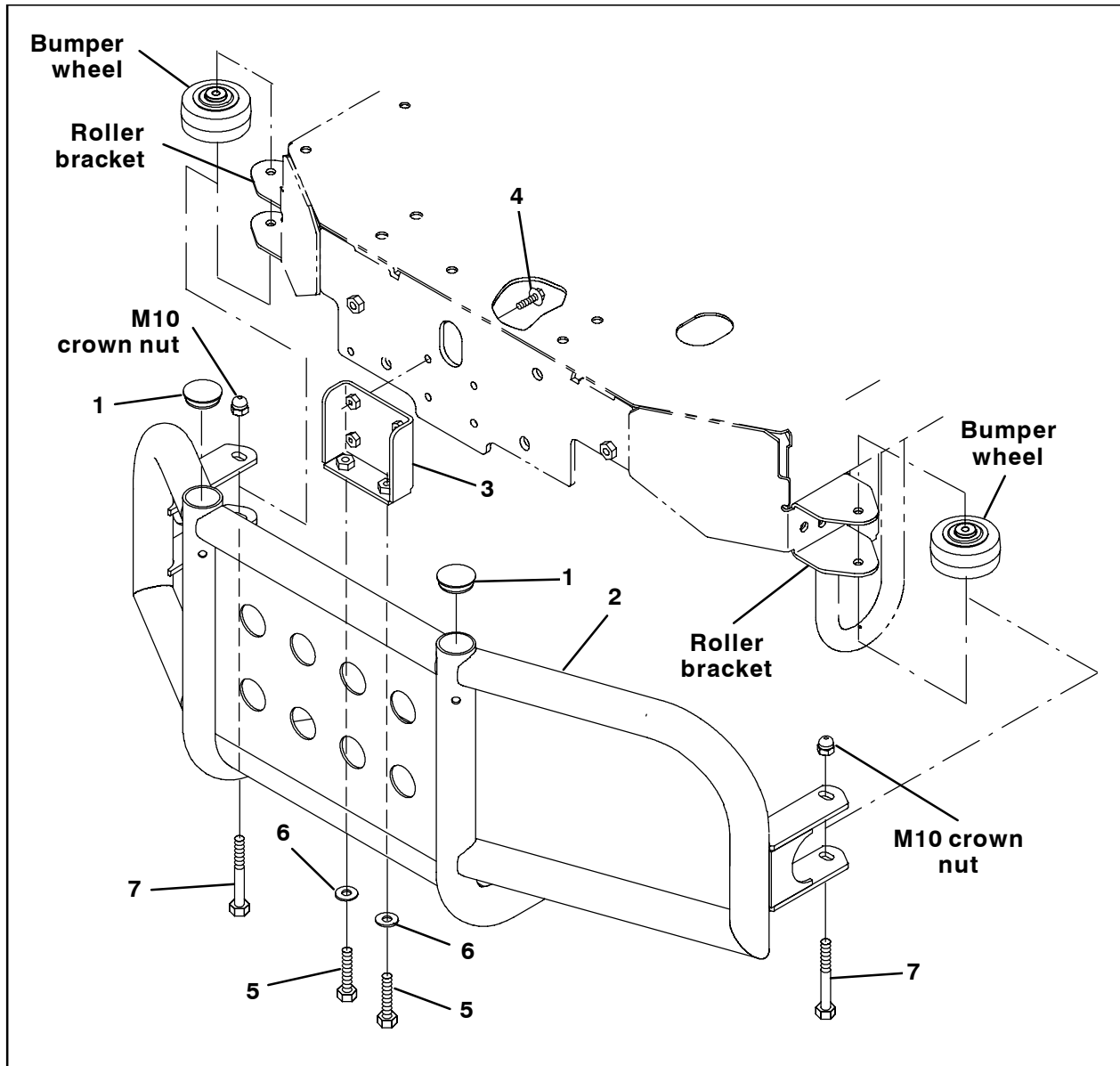

FIG. 2

Bill Of Materials For Bumper Kit, Front, CI [T16] - 9008061

	Ref.	Tennant- Part No.	Description	Qty.
▽		9008061	Bumper Kit, Front, CI [T16]	1
▲	1	1058397	Plug, Hole, Rnd, 1.50h Blind, Blk Nyl	2
▲	2	1054499	Bumper Wldt, Tube	1
▲	3	1058867	Angle, Mtg, Bmpr	1
▲	4	1037354	Screw, Hex, M8 X 1.25 X 30, 9.8, SEMS	4
▲	5	09028	Screw, Hex, M10 X 1.50 X 25, SS	2
▲	6	01686	Washer, Flat, 0.44b 1.00d .08, SS	2
▲	7	34877	Screw, Hex, M10 X 1.50 X 100, 8.8	2

TENNANT COMPANY
P. O. Box 1452
Minneapolis, MN 55440-1452